

BALTIMORE AIRCOIL COMPANY

Reliably serving your cooling process

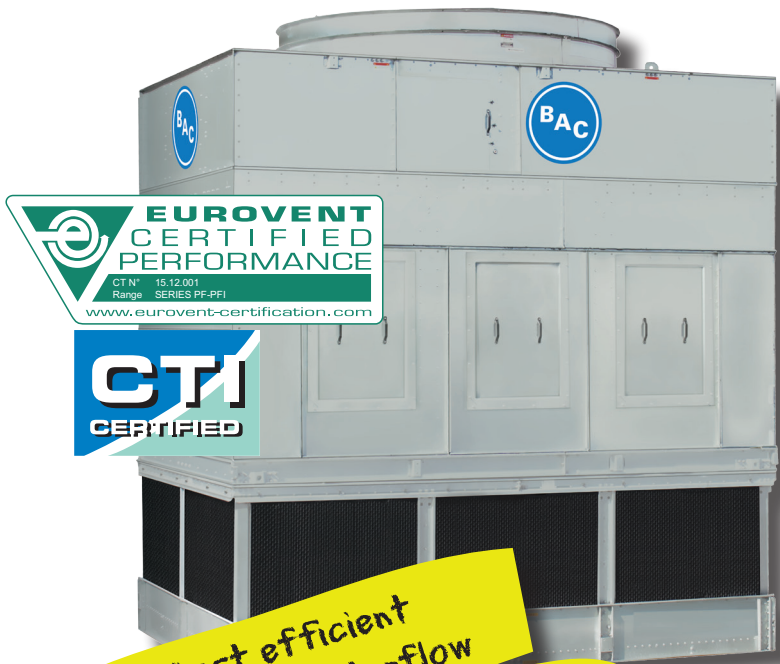

Most efficient
certified counterflow
closed circuit cooling
tower on the market.



PFI

Closed Circuit
Cooling Towers



- ✓ Lowest energy consumption and total cost of ownership
- ✓ Year-round reliable operation
- ✓ Ideal replacement unit, with certified thermal performance



**BALTIMORE
AIRCOIL COMPANY**

... because temperature matters™

PFI

Closed Circuit Cooling Towers



Baltimore Aircoil is the worldwide leading manufacturer of heat rejection equipment for a wide range of applications. In its constant search for improvement in design and performance BAC has developed and perfected many features which have become the standard of excellence for cooling throughout the world.

PFI counterflow closed circuit cooling towers are CTI-Eurovent certified, assuring you that your unit will perform in accordance with the published ratings and save a lot of system energy. The OptiCoil™ System increases thermal performance up to 30% for a given coil volume, enabling the PFI model line to offer the lowest total cost of ownership among the available counterflow cooling towers on the market. Thanks to its dry capability, the PFI is a perfect match for extremely cold weather applications.

Single cell capacity 135 - 1480 kW



Inward sliding access door allows easy access to fan drive and water distribution system for proper maintenance and inspection

Coil inspection hatches* allow easy access to heat transfer section for inspection and maintenance

Guide pins help reduce section assembly time by up to 75%

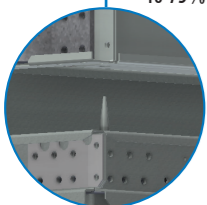

Light-weight combined inlet shields without frame, preventing collection of dirt and biological growth

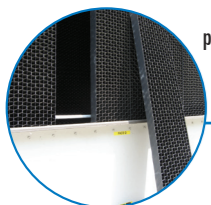

Cold water basin sloping towards drain, to prevent sediment build up

Fan drive system with heavy-duty bearings, normal maintenance like regreasing and belt tensioning can be performed from outside the unit

Heavy Duty Construction hot-dip galvanized steel panels with Baltiplus or Baltibond* Hybrid Coating



Low maintenance water distribution system large non-clogging 360° nozzles, BranchLok Removal System for easy tool-less spray branch removal

OptiCoil™ System

Combination of direct and indirect heat transfer, enhancing thermal performance up to 30% for a given coil volume and reducing the anti-freeze solution up to 60%. Coil only optionally available.

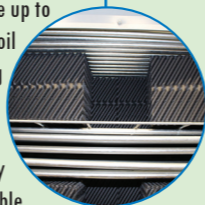

* option
The OptiCoil System™ patent is pending.

lowest energy consumption and total cost of ownership

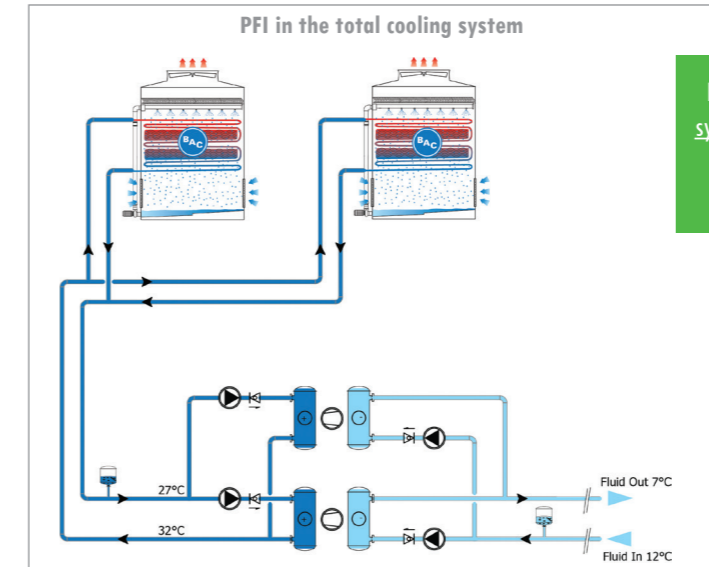

Evaporative cooling equipment can reduce the system energy consumption of the process to be cooled up to **25%** versus dry cooling (for typical chiller applications).



- **Elimination of potentially excessive operating costs** - PFI closed circuit cooling towers are CTI-Eurovent certified for both water and glycol. This guarantees thermal performance and it eliminates field thermal performance testing costs.
- **System pump energy savings** - Shorter coil circuits result in lower coil pressure drops.
- **Savings on maintenance and water treatment** - The closed loop in PFI cooling towers ensures a contaminant-free cooling circuit.
- **Lower installed costs** - PFI closed circuit cooling towers have a lower weight, reducing structural and vibration isolation costs. Less glycol is required to achieve the same or higher heat transfer.
- **Water and chemical savings up to 33%** - Baltibond Hybrid Coating* allows higher cycles of concentration.

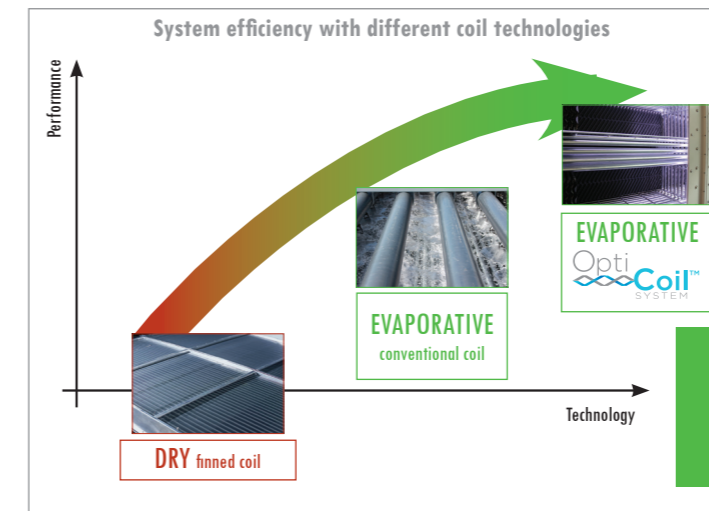

The highly efficient OptiCoil™ System increases thermal performance up to 30% for the same coil volume lowering the installed fan power by up to 50%.

year-round reliable operation

- **Trouble free process operation** - The closed loop in PFI cooling towers protects the process fluid and equipment from external contaminations.
- **Extremely cold weather operation** - The OptiCoil™ System allows dry operation.
- **Optimal thermal performance through lifetime** - Lab tests have proven that the OptiCoil™ System reduces scale formation on the coil.
- **Long equipment life** - The PFI offers a broad choice of high quality construction materials for applications with severe water conditions.
- **Minimum maintenance and downtime** - Complete and easy access to all critical components, including coil.



Lab tests have proven that the OptiCoil™ System reduces scaling.

For more information see Technical Resources document on www.BaltimoreAircoil.eu/products/PFI

ideal replacement unit

- **Same or higher capacity** - The PFI is ideal for replacement applications that require a physically like-for-like solution. The PFI closed circuit cooling tower will perform per published ratings, as the entire product line is independently CTI-Eurovent certified for various process fluids.

BALTIMORE AIRCOIL COMPANY

more than 75 years of experience and know-how

With thousands of successfully operating installations worldwide Baltimore Aircoil has the **application and system experience** to assist you in the design, installation and operation of your cooling equipment. Ongoing investment in research, combined with an advanced **R&D** laboratory facility, enables BAC to consistently offer new technologies and products to meet developing industry demands.

Baltimore Aircoil has a **network of highly qualified sales representatives** backed up by an experienced technical staff to ensure that each customer project is a success.

Sustainability is fostered and cultivated in BAC's business processes. Through our products we also help our customers to achieve their sustainability goals. You can find BAC's sustainability commitments on the website www.BacSustainability.com.

ISO 9001:2008
certified



3D-design software

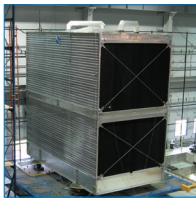

5000 m² R&D-test centre

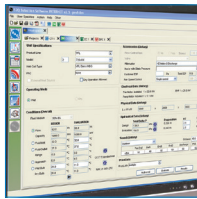

selection and simulation software



testing



high quality and sustainable
manufacturing



on site services



sustainable business processes
and culture

There is a wide variety of closed circuit cooling tower concepts available on the market. For this reason we recommend you to evaluate different cooling tower configurations for your project. Your BAC Balticare representative is available to assist you in this evaluation.

In order to select the right closed circuit cooling tower for a specific application, a number of important parameters should be considered. Listed below are questions, which should be answered when making your choice.

about the application

- What are the design conditions (flow, fluid type, in and out and entering wet bulb temperature) which achieve the best energy efficiency for my process?
- Are there acoustical limitations (sound power, sound pressure, day, night)?
- What space is available for the closed circuit cooling tower?
- How can I conduct maintenance and cleaning?
- Could the formation of visible plume represent a problem?
- What is the condition of the make-up water and how to control the recirculating water quality?

about the supplier

- How has the manufacturer established his ratings? Are the ratings independently certified?
- What is the level of the manufacturer's service and access to original spare parts?
- Can the manufacturer demonstrate compliance with directives and regulations?
- Who is my contact person for technical and commercial assistance?
- Are the manufacturers products produced in a sustainable way?

For more information visit our website at www.BaltimoreAircoil.eu or contact your BAC representative to assist you with the selection, operation and maintenance of your cooling tower installation, to ensure continuous efficiency of your process.



www.BaltimoreAircoil.eu
www.BacSustainability.com
info@BaltimoreAircoil.eu



**BALTIMORE
AIRCOIL COMPANY**

Your local contact :